

# Fulflo® XLH Filter Bags

High-efficiency for quality filtration performance

Fulflo® XLH filter bags are ideal for virtually any process filtration application requiring the removal of solids. Parker's filter bags are manufactured and tested under the strictest quality control standards to assure consistent performance.

XLH filter bags perform at efficiencies similar to depth cartridges with high flow rates and viscosities to 10,000 cps or higher. XLH bags are available in 0.5µm, 1µm, 2.5µm, 10µm and 25µm particle retention ratings.



## Contact Information

Parker Hannifin Corporation  
**domnick hunter**  
**Process Filtration - North America**  
2340 Eastman Avenue  
Oxnard, California, USA 93030

toll free +1 877 784 2234  
phone +1 805 604 3400  
fax +1 805 604 3401  
dhpsales.na@parker.com

[www.parker.com/processfiltration](http://www.parker.com/processfiltration)

## Benefits

- Parker's XLH all-polypropylene high efficiency filter bags provide twice the dirt-holding capacity at a lower cost than many competitive bags and cartridges of the same micrometer rating
- XLH bags require less frequent change out, less storage and disposal space, and are easy to install and remove
- Each bag is incinerable (with Quik-Seal™ option), reducing filter disposal costs
- All materials of construction are FDA listed as acceptable for potable and edible liquid contact according to CFR Title 21
- ISO 9001 registered company

## Applications

- Solvents
- Bulk Chemicals
- Coatings
- Coolants
- Petroleum Oils
- Inks
- Paints
- Adhesives
- Resins
- Prefilters for Finer Cartridges
- Parts Washing Systems
- Water

# Fulflo® XLH Filter Bags

## SPECIFICATIONS

### Materials of Construction

**Microfiber:** FDA grade polypropylene microfiber used in the XLH bag series assures high-efficiency performance and is oil absorbent.

**Particle retention ratings:**  
0.5µm to 25µm

### Maximum Recommended Operating Conditions

**Temperature:**  
Polypropylene—200°F (94°C)  
Flow Rate (Per single length)  
XLH 25gpm (95 lpm)  
Change-out ΔP: 35psi (2.4bar)

**Maximum Allowable Pressure:**  
70psid (4.8bar)

**Standard Seal:**  
(No seal option specified)  
C = Plastic Quik-Seal Ring  
G = Galvanized Steel Ring

### Size

C1: 7.5" X 17.5"  
C2: 7.5" X 31.5"  
G1: 7" X 17.5"  
G2: 7" X 31.5"

### XLH Flow Factors

Rating (µm)	Flow Factors
0.5	0.0185
1	0.0143
2.5	0.0130
10	0.0043
25	0.0031

### XLH Filter Bag Retention Ratings

Rating (µm)	Particle Size (µm) at which efficiency is:		
	90%	95%	99%
0.5	0.5	1	5
1	1	2	10
2.5	2.5	4	16
10	2.5	4	16
25	25	30	40

### Flow Rate and Pressure Drop Formulas

Flow Rate (gpm) =  $\frac{\text{Clean } \Delta P \times \text{Length Factor}}{\text{Viscosity} \times \text{Flow Factor}}$

Clean ΔP =  $\frac{\text{Flow Rate} \times \text{Viscosity} \times \text{Flow Factor}}{\text{Length Factor}}$

#### Notes:

- Clean ΔP is psi differential at start.
- Viscosity is centistokes. Use Conversion Tables for other units.
- Flow Factor is ΔP/GPM at 1 cks for single length bag.
- Length Factors convert flow or ΔP from single length bags. Use length factor or 1 for single length and a factor of 2 for double length.

#### Beta Ratio (β):

Upstream Particle Count @ Specified Particle Size & Larger  
Downstream Particle Count @ Specified Particle Size & Larger

$$\text{Percent Removal Efficiency} = \left( \frac{\beta - 1}{\beta} \right) \times 100$$

## Ordering Information

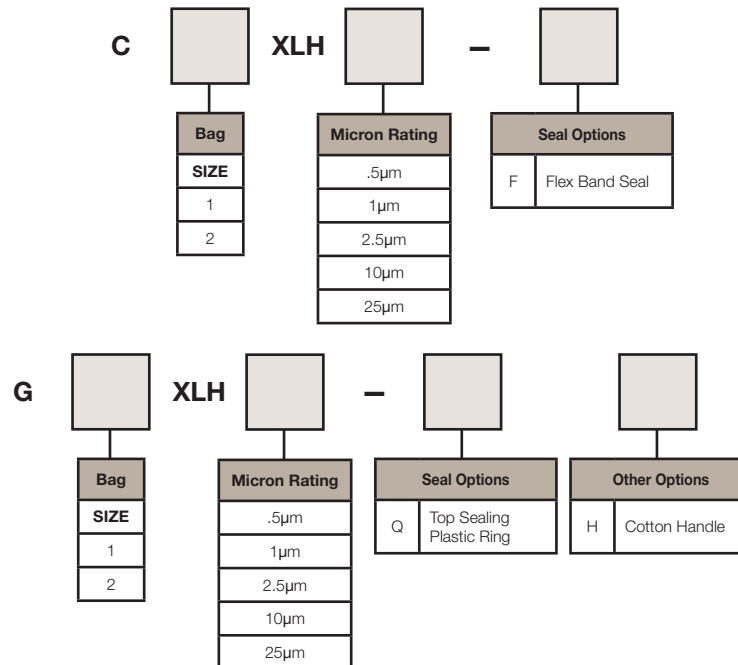

Specifications are subject to change without notification.  
For User Responsibility Statement, see [www.parker.com/safety](http://www.parker.com/safety)

© 2010 Parker-Hannifin Corporation  
domnick hunter Process Filtration - North America  
All Rights Reserved

Fulflo is a registered trademark of Parker-Hannifin Corporation

DS\_IP\_XLH Filter Bag Rev. A